

WHITEPAPER

SPEECH EXPERTS
Gesellschaft für innovative
Sprachtechnologie mbH
Bruderwöhrdstraße 15 b
93055 Regensburg
Fon: +49.941.604 889 41
Fax: +49.941.604 889 42
info@speech-experts.com
www.speech-experts.com

SPEX KIT Dialog Platform

The SPEX KIT dialog platform enables the development of flexible and natural speech dialogs for multi-application purposes.

The **Dialog Manager** is the heartpiece of the SPEX KIT. It supports mixed initiative dialog management, flexible switching between subdialogs, direct and indirect options for correction, explicit and implicit confirmations and user friendly prompts.

The Dialog Manager is configured via the **SDML (Smart Dialog Modeling Language)**, an **XML-based script language**. SDML is a compact and easy-to-handle high-performance script language. An additional advantage is its ability to develop dialog systems efficiently and at low cost. The insert below shows an example of how to enter a telephone number.

```

<Subdialog Name="S_VoiceDialing">
  <Step Name="s_vioceDialing_number_main">
    <SpeechOutput>
      <Playlist Prompts="p_request_number"/>
      <Playlist Prompts="p_sorry p_request_number_shortHelp"/>
      <Playlist Prompts="p_sorry p_request_number_longHelp"/>
    </SpeechOutput>
    <SpeechInput Subgrammars="digit_entry"/>
    <ActionSequence Condition="digits = ANY">
      <Action String="store lastBlock"/>
      <Action String="request number"/>
    </ActionSequence>
    <Transition Condition="digits = ANY"
      Target="s_voiceDialog_number_continue"/>
    <Transition Condition="command = back_main"
      Target="S_VoicePortal_Main"/>
    <Transition Condition="command = help"
      Target="s_voiceDialing_number_help"/>
  </Step>

```

System Features

Operating System

Windows 9x
ME, / NT / 2000 / XP

Audio I/O

Soundcard, CAPI / ISDN

Speech Recognition

TEMIC Starrec
IBM ViaVoice

Grammar

JSGF

Speech Synthesis

SVOX, ELAN TTS Engine
ELAN SpeechCube

Database Link

ODCB

Other Interfaces

DLL, TCP/IP
Windows Messaging

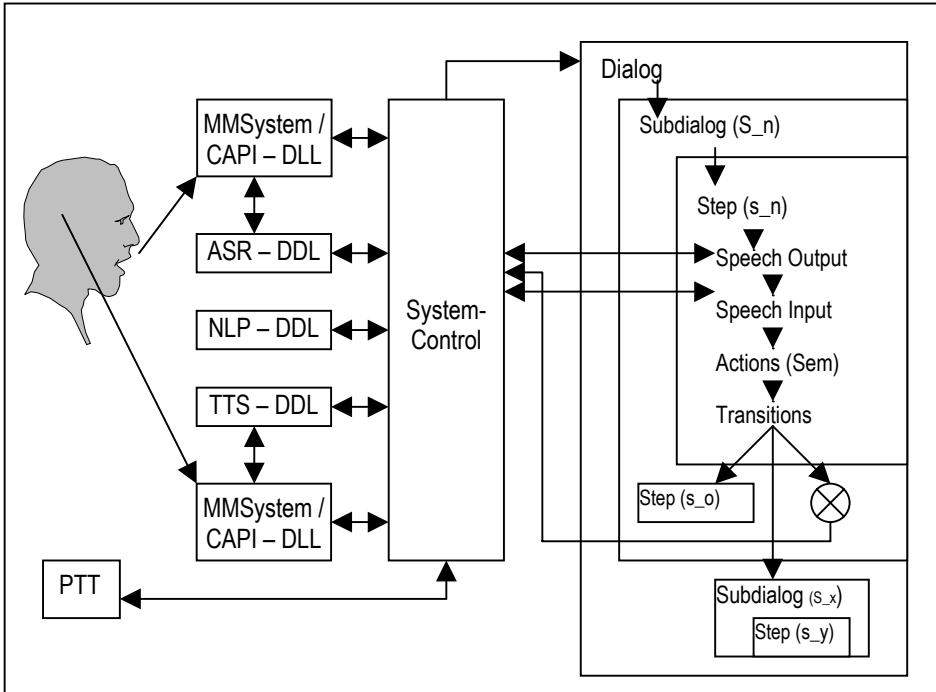

Linking Components

Another advantage of using SPEX KIT is its **open architecture**. The speech processing components (*speech recognition, speech understanding, speech synthesis and text generation*) are located within a special framework. The modules can therefore be linked up with one another at will, depending on customer specifications, without changes having to be made to the dialog.

Linking the Modules with the Dialog Manager

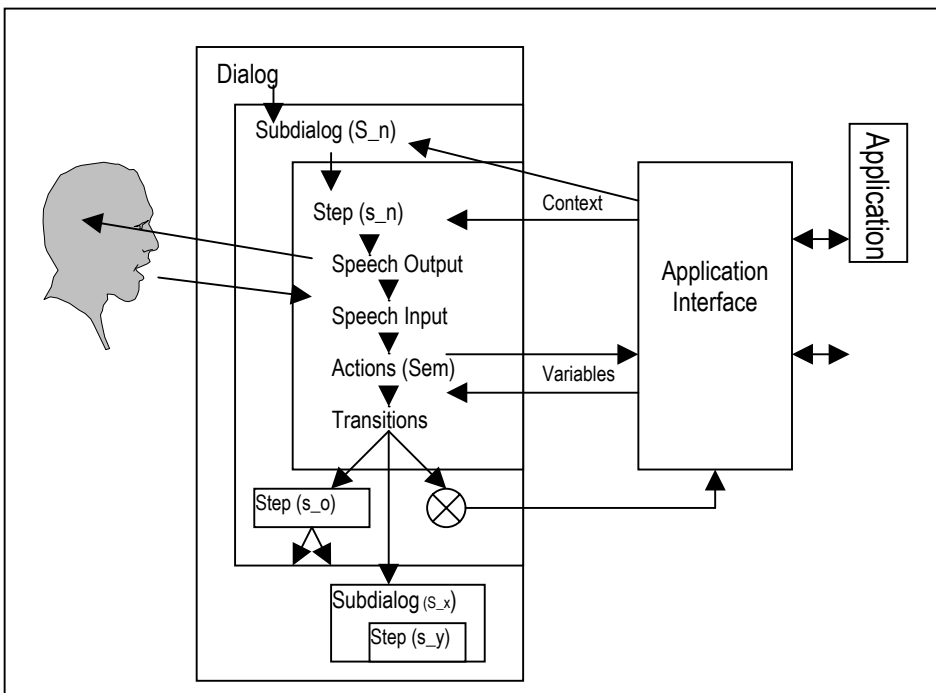

You as our customer have the choice of which components in which combination best suit your needs.

System Link-up

Telephone Dialog Systems

SPEECH EXPERTS develops intelligent telephoning based on dialog systems. Callers interact with and talk to the system in a natural way, which is especially enabled by the support of a flexible dialog. The caller does not get ensnared in rigid menus and, if the needs arises, can fall back on the assistance provided by the system.

We will customise your dialog system to suit your needs and those of your customers. The applications will be stored locally on a PC. All you need is an ISDN card.

Our dialog systems are designed for multi-purpose use, for instance, for the automatic rerouting of calls and information services or for accounting systems.

Examples of Applications

- Automated Operators
- Dynamic Call Routing
- Information Systems
- Telephone Intranet
- Ordering Systems
- Accounting Systems

Dialog Specifications and Demonstrators

SPEECH EXPERTS' core competence is its in-depth know-how for the development of speech applications and related services. Dialog specifications and demonstrators are the core components. Based on these you can implement your own dialog systems, for instance in the Embedded area.

Our dialog specifications are based on a detailed analysis of the application environment and the target group. This is how we are able to optimise dialog management to suit your special needs and create a natural and simple system for users.

The dialog platform is made up of sophisticated modules which can shorten the time to implementation of speech systems for demonstrators and user tests. We will also carry out usability tests for any dialog systems you have developed yourself, with the additional benefit of delivering objective test results.

Services

- Application Analysis
- Target Group Analysis
- Dialog Spezifikation
- Dialog Demonstrators
- Usability Testing
- One-stop Consultancy
Services for Speech
Technology

Company Profile

SPEECH EXPERTS was founded in 2002 as a company with limited liability. The company has over 15 years of experience in the research and development of speech technology.

Our core competences comprise dialog design and specification, rapid prototyping and the evaluation of dialog systems and multi-modal systems.

The founding members of the company have been involved in a number of projects with prime companies such as Audi, Bosch-Siemens Household Appliances, DaimlerChrysler, Ericsson, Sony, Telekom, Temic and Toshiba.